

Norwell

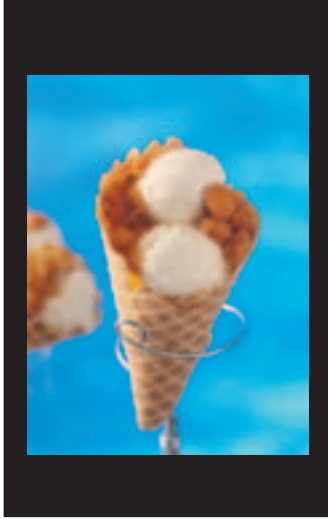

*An adaptable display
designed to boost impulse sales*



Frozen products

Ice creams

Packed products

Dairy products

Delicatessen products

Convenience foods

A versatile display that increases impulse sales

The Norwell freezer island is extremely effective in prompting shoppers to make impulse purchases. Its small size means that it can be located practically anywhere. It is difficult for shoppers to pass a Norwell island without buying when the products in its glass display can be clearly seen from long distances and all directions.

The Norwell display island is suitable for all types and all sizes of stores and shops - from supermarkets to convenience stores and from service stations to kiosks.

Ideal for brand marketing

The Norwell display can be stylishly and flexibly adapted to promote different branded products. Advertising signs and logos can easily be taped to the side panels of the display island and changed as needed. Mounted on castors, it is easy to move from one location in the shop to another whenever the need arises.

Dependable temperatures, eye-catching design

The Norwell display island is available as refrigerator, freezer or combination unit. The temperature of the chest remains constant throughout the unit, ensuring safe storage for all products. An optional plastic cover also protects against radiated heat and external airflows. Norwell display islands are the ultimate in stylish design. The lighting which encircles the entire unit highlights and promotes the products in the display, with the sole intention of attracting the shoppers' eye.



Norwell-150-FF
Eye-catching product display, height 280 mm

Norwell-150-FC

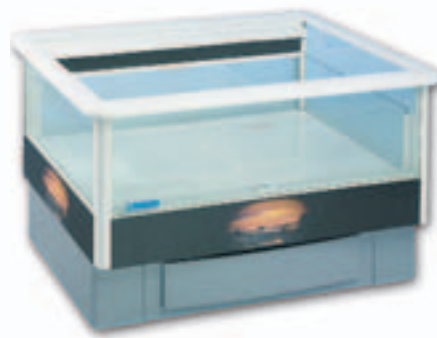

Norwell-150

Construction

- load-bearing structure and outer shell: All visible elements of the top part are made of aluminium profile. The grey base element and the detachable panels in the top part are made of galvanized steel sheet
- the glass panel beading encircling the unit is also made of aluminium
- high quality, durable stove enamelling
- insulation is pressure-foamed polyurethane applied by an automated machine, causing no harmful effects to the ozone layer
- castor wheel mounting for ease of movement around the shop
- the high glass edge maximizes the visibility of products in the unit

Dimensions

- external dimensions: 1514 x 1054 x 915
- internal dimensions: 1295 x 765 x 280
- height of display cabinet 280 mm in all models

Standard equipment

- integrated cooling machinery with fan evaporator
- automatic defrosting and drainwater evaporation
- connection lead with earthed plug
- castor wheels (4)
- lighting all around the unit on the top edge of the glass panel

Optional accessories

- plastic cover
- advertising light (2 separate lights)
- brake (2 pcs per unit)
- partition dividers
- electric socket on base
- exchangeable side panels

Models

- refrigerator unit (C) +2...+4°C
- refrigerator/freezer unit (FC) +1...+3°C / -23...-21°C
- freezer unit (FF) -26...-23°C
- FC model with electric defrosting
- FF model with hot gas defrosting

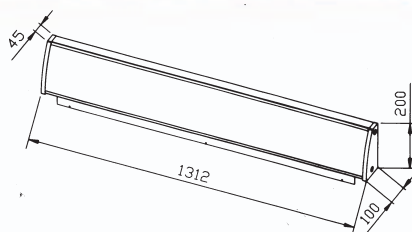

Advertising light for installation on edge of glass panel on fan side. Lighting aperture for advertisements 1280 x 185 mm.

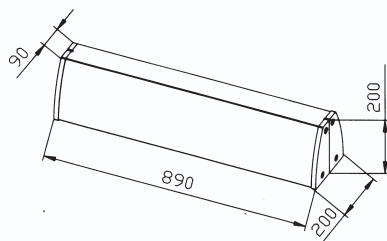

Transverse advertising light. Lighting aperture for advertisements 860 x 185 mm.

Model	Air temperature °C	Connected load W	Capacity l	Length mm	Width mm	Height mm
Norwell-150-C-M	+2...+4	1390	277	1514	1054	915
Norwell-150-FC-SS-SH-M	-23...-21	2710	277	1514	1054	915
Norwell-150-FF-KS-SH-M	-26...-23	2390	277	1514	1054	915

Technical specifications at ambient temperature of +25°C and relative humidity of 60 %.
Connection voltage 230 V, single-phase, 50 Hz.

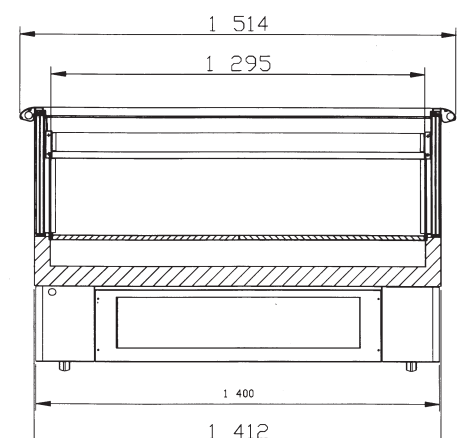
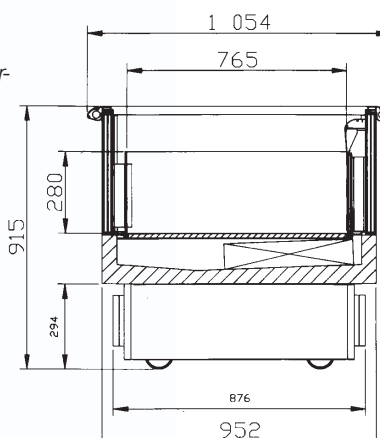

Norpe Ltd.

P.O.Box 24 (Teollisuustie 7)
FIN-06151 Porvoo, Finland
Tel. +358 204 86 5020
Fax +358 204 86 5350
www.norpe.fi
www.norpe.com
marketing@norpe.fi

Norpe AB

Box 7124 (Urviksvägen 129)
S-174 07 Sundbyberg, Sweden
Tel. +46 8 594 112 00
Fax +46 8 594 112 19
www.norpe.se
info@norpe.se

Vibocold

Bruno Simonsen A/S
Livøvej 22
DK-8800 Viborg, Denmark
Tel. +45 86 61 3411
Fax +45 86 61 3764
mail@vibocold.dk

Norpe Russia

Ul. Shpalernaya 36, office 414
RU-191 123 St.Petersburg, Russia
Tel. +7 812 273 3912
Fax +7 812 118 81 85
www.norpe.com.ru
sale@norpe.spb.ru

Norpe U.K. LTD.

Mersey House
220 Stockport Road, Cheadle Heath,
Stockport SK3 0LX, Great Britain
Tel. +44 161 428 9225
Fax +44 161 428 1186
www.norpe.co.uk
info@norpe.co.uk

Norpe AS

Borgeskogen næringspark S
N-3160 Stokke, Norway
Tel. +47 33 36 35 00
Fax +47 33 36 35 01
www.norpe.no
post@norpe.no

Norpe Eesti Oü

Saku 15
11314 Tallinn, Estonia
Tel. + 372 656 1717
Tel/Fax + 372 655 6463
www.norpe.ee
info@norpe.ee

Norpe Polska Sp. z o.o.

Al. Jerozolimskie 154
PL -02362 Warszawa, Poland
Tel. +48 22 882 00 20
Fax +48 22 882 00 19
www.norpe.pl
norpe@norpe.pl

We reserve the right to make changes and modifications.

